

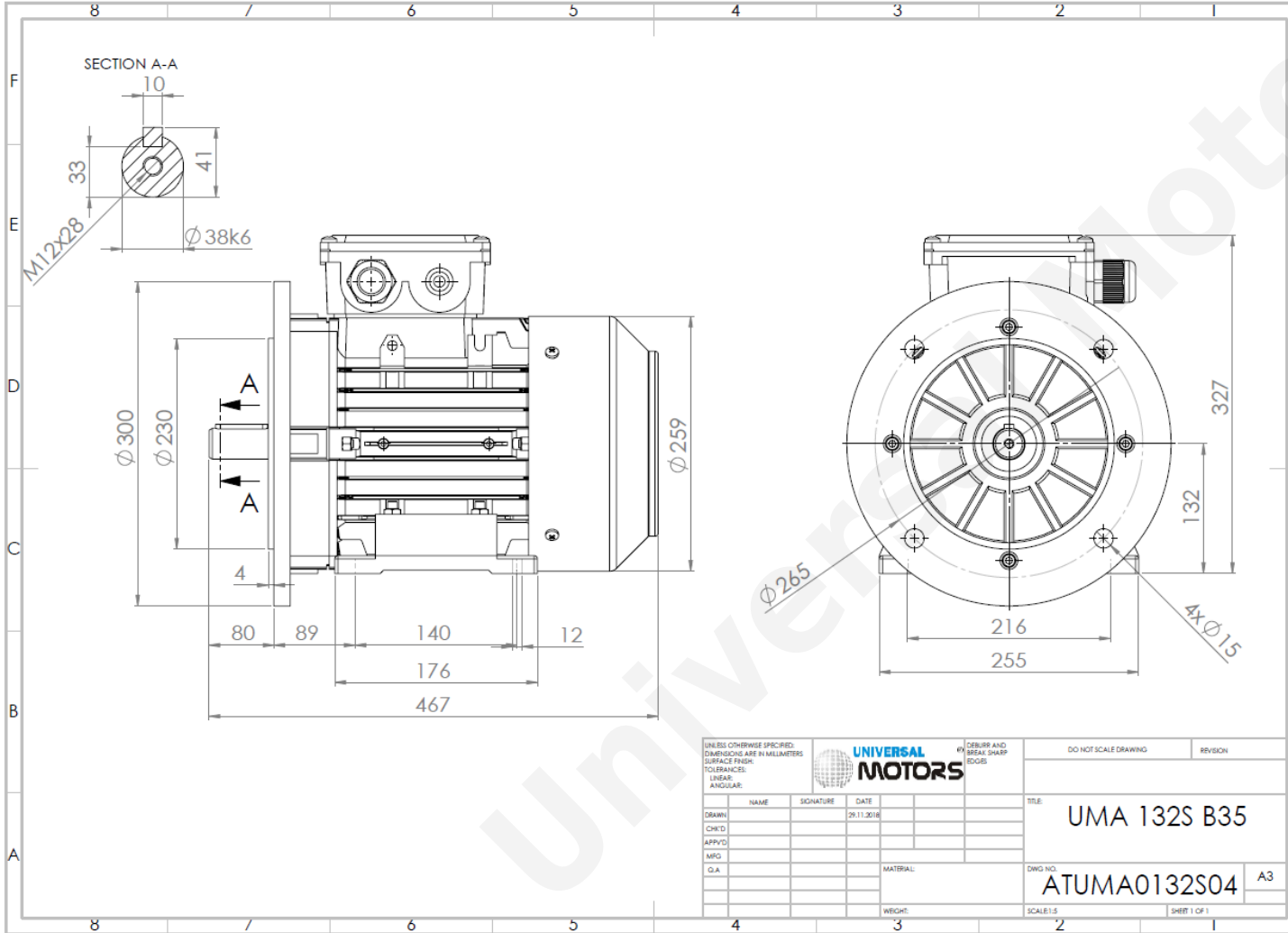

TECHNICAL DATA

Three Phase Electric Motors - Aluminum Frame
 UM3A 132 S2 2 IE3
 7.5 kW / 10 Cv
 RPM



| | |
|-------------------------|--------------------------|
| Motor type: | UM3A 132 S2 2 IE3 |
| Output: | 7.5 kW / 10 Cv |
| Frequency: | 50 Hz |
| Voltage: | 400 V |
| Current: | 13.1 A |
| Power factor (Cos Ø): | 0.92 |
| Poles: | 2 |
| Insulation class: | F |
| Temperature rise Class: | B |
| Efficiency 50%: | 90.7 % |
| Efficiency 75%: | 90.9 % |
| Efficiency 100%: | 90.1 % |
| Torque: | 24.4 N.m |
| Tstarting/Tnominal: | 2.6 |
| Istarting/Inominal: | 10.1 |
| Tmaximum/Tnominal: | 3.6 |
| Noise: | 80 Db(A) |
| Weight: | 51.7 Kg |
| Brake AC: | AC7 |
| Torque Brake DC: | 80 N.m |
| Bearing DE: | 6308 2Z |
| Bearing NDE: | 6308 2Z |
| Torque Brake AC: | 90 N.m |
| Brake DC: | REB-05-16 |

Regime - S1

Altitude - 1000m

Environment Temperature - 40°C

CONTACTS:

UNIVERSAL MOTORS Tel: +351 252 299 080
 Rua de São Brás,745 Fax: +351 252 299 089
 4480-782 VILA DO CONDE Mail: geral@universalmotors.pt

* References applied only in the UK